

Brighten Up® Series installation guide

Solatube 160DS (250mm Ø) and Solatube 290DS (350mm Ø)



SOLATUBE Parts List



Roof dome with patented Raybender® 3000 technology



Top tube assembly (305mm long) incorporating 0-30° adjustable angle and dome ring



Roof flashing to suit specified roof type
(*Solatube 160DS slate/plain tile roof flashing shown*)



Bottom tube assembly (305mm long) incorporating 0-30° adjustable angle and ceiling ring with integrated twist lock mechanism— see *note right re additional extension tubes*



Double glazed diffuser



Seal & fastener kit
LightTracker™ dome reflector
Flashing sealant - if required
Aluminium tape roll
Flashing screws (50mm)
Dome ring screws (25mm)
Tube screws (10mm)
Expansion joint seal

Please read these instructions fully before beginning installation

Additional extension tubes?

You will receive a top tube and bottom tube assembly in your Solatube kit. Together these assemblies give an install distance (roof to ceiling) of up to 400mm (16"). This is generally sufficient for flat roofs, vaulted ceilings, or very shallow pitch roofs. For greater install distances please check you have purchased sufficient extension tubes to meet your required install distance:

Up to:	Ext Tubes:
400mm (16")	0
960mm (38")	1
1520mm (60")	2
2080mm (82")	3
2640mm (104")	4
3200mm (126")	5
3760mm (148")	6
4320mm (170")	7

Important notice

Please ensure that all components have arrived in perfect condition before starting the installation.

If any components are damaged in transit, the complete, unused system should be returned for replacement.

We do not accept return of individual system components.

Please note that top & bottom tube assemblies are delivered one inside the other.

Warning

Do not proceed with the installation until you have read and understood the entire installation guidelines, including the points below. If you have any questions or require clarification of any installation procedures, please contact your Solatube® supplier.

Solatube (or seller) assumes no responsibility or obligation whatsoever for the failure of an architect, contractor, installer or building owner to comply with all applicable laws, ordinances, building codes, energy codes, fire and safety codes and requirements, and adequate safety precautions. Installation of this product should be attempted only by individuals skilled in the use of the tools and equipment necessary for installation. The supplier accepts no responsibility for incorrectly installed or non-appropriate applications. Protect yourself and all persons and property during installation. If you have any doubt concerning your competence or expertise, consult a qualified expert before proceeding. In addition, please check the Health & Safety Executive website for advice on safe working at height <http://www.hse.gov.uk>. Installation is at your own risk.

Solatube product installations may be dangerous owing to the locations of the work to be undertaken. The hazardous conditions include, but are not limited to, the following:

- During installation, the Solatube reflective tubes may focus sunlight potentially causing concentrated light and heat. Keep the protective film on the reflective tubing prior to installation and the tubing away from potentially flammable material.
- Sheet metal edges may be sharp. Use protective gloves to avoid lacerations.
- Installation requires climbing and working at dangerous heights, including on ladders, scaffolding, roofs and in attic spaces. Use extreme caution to minimize risk of accidental injury and property damage including, but not limited to, the points below:
 - Clear the area below your workspace of all people, animals and other items.
 - Avoid working on surfaces that are slippery or wet and use footwear with excellent traction.
 - Use only strong, well-supported and appropriate ladders.
 - Work only in calm, dry weather.
 - When in the attic, ensure that your weight is supported at all times with structurally sound framing; dry wall material is not designed to carry a person's weight.
 - Reduce the risk of fire, electric shock, and personal injury by following basic safety precautions when using electric tools; always wear safety goggles or other suitable eye protection and ensure work area is clear of all electrical wires, gas pipes, water pipes and other obstacles.
 - When working in the attic or other dusty areas, use of a mask or respirator is recommended to avoid lung irritation. Attic spaces may be dark, confined, and subject to extreme temperatures. Beware of sharp protruding objects. Do not attempt installation without having someone within range of your voice or close enough to come to your aid if necessary.
 - Only suitably qualified persons should undertake any electrical wiring.

Installation tips & safety advice

These instructions are a step-by-step guide for the installation of a Solatube 160DS and 290DS.

In general, a Solatube 160DS can provide enough daylight to illuminate a dark area of up to 13 sq m (150 sq ft). A Solatube 290DS can provide enough daylight to illuminate a dark area of up to 22 sq m (250 sq ft). Both examples are based on a 2.44 m (8ft) ceiling height with a 1.83 m (6 ft) tube length. For larger areas, you may need to install more than one Solatube. This information is for guidance purposes only.

Allow at least 4 hours for the installation, particularly if this is your first installation.

During the day, turn off all the lights in the room to see how much natural light comes in through the windows (if any). You should then be able to determine the best position for the Solatube diffuser.

Avoid roof dome locations shaded by trees, ridges and chimneys, or near water channels or valleys.

Avoid attic areas with obstructions such as gas, water or drain pipes, air ducts, flues or furnaces, fixed storage tanks.

Measure the distance between the roof and the ceiling to ensure you have ordered sufficient reflective tubing to cover the distance.

All reflective extension tube joints should overlap a minimum of 50mm and be fixed together using the self-tapping screws and aluminium tape provided.

All adhesives, seals and tapes should be applied to a dry surface. The ideal working temperature is approximately 22°C.

Ensure your roof is in an appropriate condition to support the work necessary for a Solatube installation without damaging its waterproofing properties.

Solatube will generally perform best if the roof dome is located on the south, east or west elevation. If the roof dome is to be positioned on a north facing elevation, positioning the roof dome as high as possible on the roof will enhance performance.

You may choose to support any extension tubes with a wire or similar retainer fixed to the rafters if the extension tubes are at an angle away from the vertical.

In particularly cold climates, it is advisable to tape a jacket of insulating material (not provided) around the outside of the extension tubes and up into the void between the top tube assembly and roof flashing to prevent the possibility of condensation build-up on the exterior of the components within the roof void. Contact your Solatube supplier if you have any questions. When the Solatube is installed, it is common for it to condensate lightly on the inside of the dome for the first few weeks until humid air inside the tube dissipates. The dome is designed to collect internal moisture and direct it to the outside of the flashing. The Solatube is completely sealed at the ceiling level to prevent warm moist air from inside the house migrating up the tube.

Solatube optional accessories

If you have purchased any of the following optional Solatube accessories, please read the instructions supplied with the accessory before proceeding with the Solatube installation as some accessories cannot be installed as a retrofit.

Optiview® diffuser

Available for both Solatube sizes, the technologically advanced OptiView® diffuser uses a multiple Fresnel lens system with a stunning architectural look to deliver crystal clear daylight. To fit this accessory, follow the installation instructions in this guide.



Electric daylight dimmer kit*

Available for all Solatube sizes, controls the amount of daylight required from the convenience of a low voltage switch.



Integral electric light kit*

Available for both Solatube sizes, provides the convenience of a switched light for night time use.



Additional 0-90° angle

Available for both Solatube sizes, allows easy installation around obstructions or corners.



Bathroom ventilation kit*

Available for the Solatube 160DS only, offers discreet style and high performance, ideal for bathrooms and shower rooms.



Manual daylight dimmer

Available for both Solatube sizes, ideal for bedrooms, extension pole supplied for high ceilings.



*These items require connection to an electrical circuit and therefore must be installed by a qualified person

Suggested tools

- drill and drill bits
- screwdrivers
- hammer
- wire for probing
- sealant gun
- magnetic compass
- angle grinder/roof tile cutter/slate claw – subject to roof type
- sabre or reciprocating saw
- keyhole saw
- tape measure
- plumb line
- scissors or blade knife
- retaining wire (less than 3mm thick)
- torch

If you have any questions regarding the installation of your Solatube please do not hesitate to contact us – we shall be delighted to help.

0845 4580101 (local rate) or 01234 241466



SolaLighting Limited

23 Osier Way, Olney Office Park, Olney MK46 5FP

... Tel 01234 241466 Fax 01234 241766 Web www.solatube.co.uk Email daylight@solatube.co.uk

Registered in England, 6 Corunna Court, Corunna Road, Warwick CV34 5HQ Registration No 3938764

Step 1 Selecting the location for the diffuser in the ceiling

You will need a minimum clearance between joists of 275mm for the Solatube 160DS, and 375mm for the Solatube 290DS (**diagram A**). Ensure that no obstacles, pipes, wires or vent ducts are directly above this location or potentially between the diffuser location and the roof flashing position. If obstacles exist, move to a different location and check again for clearance. Mark the position of the centre of the hole to be cut and ensure you can locate it from within the roof void.

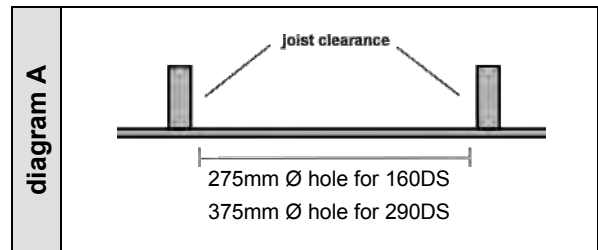

Step 2 Selecting the location for the roof flashing

The roof flashing can be positioned either vertically above the diffuser position or up to an angle of 30° from vertical in any direction from the diffuser position by rotating the two angle adaptors supplied (**diagram B**). The diagram shows two possible positions for the roof flashing relative to the position of the top and bottom tube assemblies.

Note: 0-90° angle adaptors are available if a greater degree of variation is required.

Cut a small hole in the roof felt and identify the roof position (tile) from inside so you can locate it again later from the roof side.

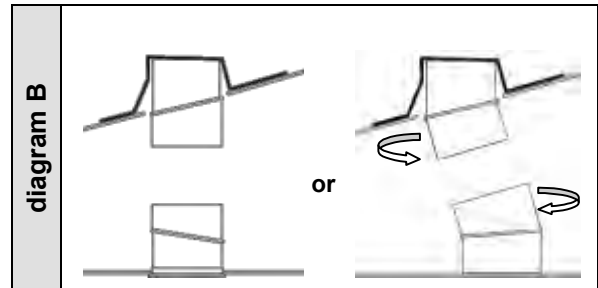

Step 3 Cutting the ceiling hole

Do not cut the ceiling hole until you are sure that the roof flashing will fit in the desired location and that the top and bottom tube assemblies will align.

Mark a 275mm circle for the 160DS or a 375mm circle for the 290DS using your centre mark (from Step 1) as a centre point for the hole. Cut the hole in the ceiling as marked (**diagram C**).

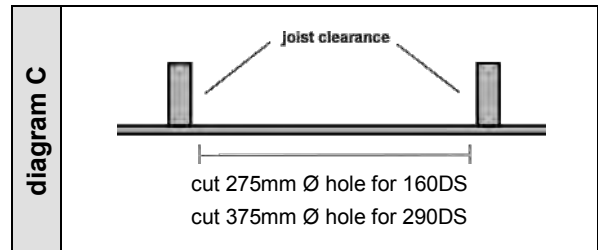

Step 4 Installing the bottom tube assembly

Insert the bottom tube assembly up into the ceiling and, if the installation is not vertical, rotate the angle adaptor to point towards the roof flashing location. Using a crosshead screwdriver, rotate and tighten two of the twist-lock fastening clamps to temporarily attach the bottom tube assembly to the ceiling (**diagram D**). Do not remove the protective liner from the inside of the bottom tube at this point.

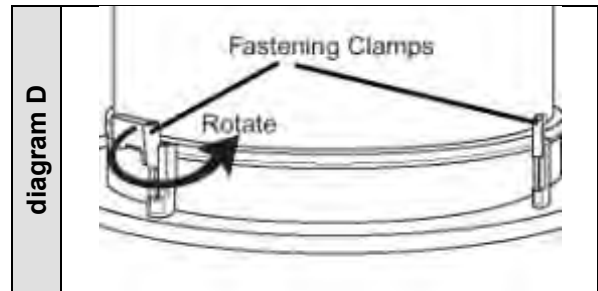

Step 5 Installing the roof flashing

To install the appropriate roof flashing for your roof type, please refer to the roof flashing installation instructions that start on page 7.

The roof flashing is supplied according to the roof type/flashing you specified on your order – **please ensure you have the correct roof flashing before proceeding.**

Step 6 Aligning the top tube assembly

Insert the top tube assembly into the roof flashing from the outside. For metal roof flashings that have pre-drilled holes ensure the dome ring screw holes are aligned with these pre-drilled holes. Non-metal flashings do not have pre-drilled holes.

Manually screw one dome screw into the flashing through a pre-drilled hole in the metal flashing or directly into a non-metal flashing to hold the top tube assembly temporarily in place.

If necessary, rotate the angle adaptor so that the top tube assembly points towards the bottom tube assembly in the ceiling. The lengths "L1" and "L2" (**diagram E**) should be equal to ensure alignment.

Note: For flat roof/vaulted ceiling applications where no extension tubes are required, the bottom tube assembly will be fitted up inside the top tube assembly.

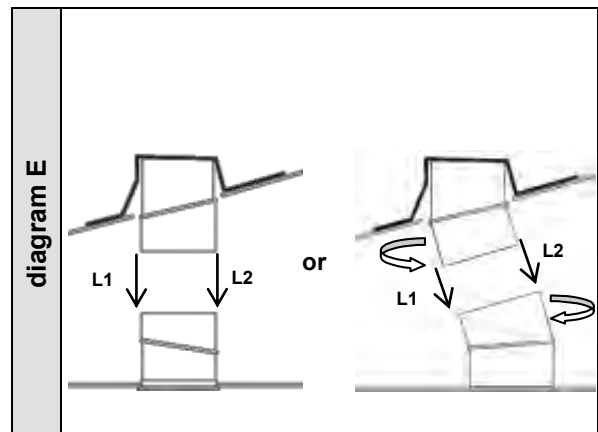

Step 7 Installing the top tube assembly

Unscrew the holding dome screw and remove the top tube assembly from the roof flashing. Tape the angle adaptor joint and tube seams of the top tube assembly with the foil tape provided (**diagram F**).

Remove the protective lining film from the inside of the tube and place the top tube assembly back into the roof flashing, aligning it again with the bottom tube assembly. Securely fasten the top tube assembly to the flashing with the dome screws provided (into the pre-drilled holes in metal flashings or directly into the upstand of non-metal flashings).



Step 8 Inserting the LightTracker™ reflector in the dome

Using a magnetic compass if necessary, position the LightTracker™ dome reflector in the north side of the dome, with the reflective side facing due south. Align the holes in the reflector with the tabs inside the dome and snap into place. Peel the protective film from the reflector (**diagram G**).

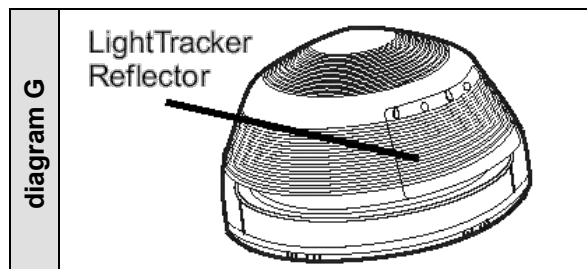

Step 9 Installing the roof dome

Keeping the LightTracker™ on the north side of the dome facing south, align the four tabs on the dome base with the snaps on the dome ring and press down firmly to click into place. Check to make sure the snaps are fully engaged (**diagram H**).

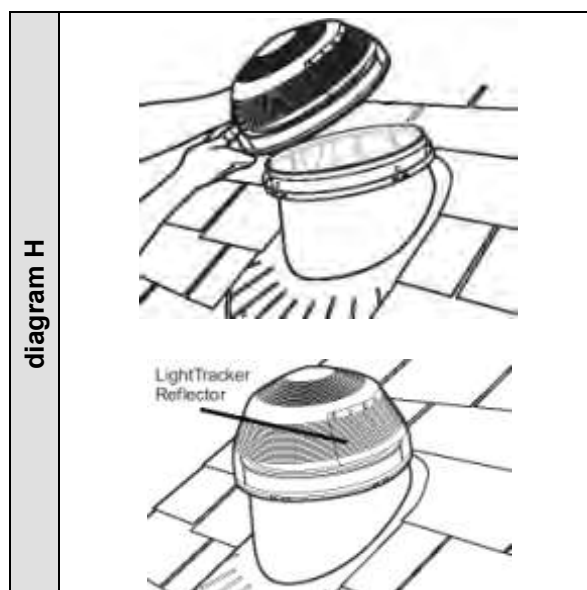

Step 10 Connecting the top tube assembly to the bottom tube assembly

For short installations with no extension tubes proceed to **Step 12**.

For longer installations with extension tubes continue to **Step 11**.

Step 11 Assembling extension tubes

Remove the protective liner from the extension tube(s) before assembly. Extension tubes have deep and shallow notches at each end so that they may be formed into slightly tapered tubes. Weave one end of the tube through a deep notch, the other end through a shallow notch, ensuring the tube is also held in the centre notch (**diagram I**). Tape the tube seam with a short piece of foil tape at either end to hold the joints temporarily in position. The smaller diameter tube end should always point towards the bottom tube assembly. Assemble all the required extension tubes, telescoping them together to provide the total length of tube required and remembering to allow at least 50mm overlap at each join. At this stage, use small pieces of foil tape to hold the tubes together. Check that the assembled tube length is correct by holding the extension tube(s) alongside the top and bottom tube assemblies. Adjust the tube length as necessary.

For very long or angled tube lengths, self-tapping screws are provided to fasten the extension tubes together. Tape all joints.

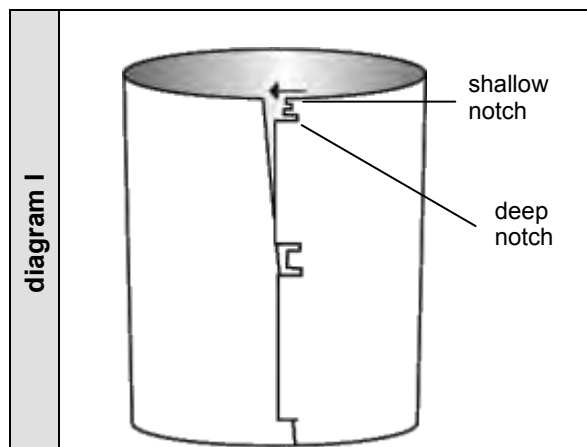

Step 12 Applying the expansion joint seal

For short installations with no extension tubes the expansion joint seal is applied 25mm from the top edge of the bottom tube assembly.

For installations using extension tubes, the expansion joint seal is applied 25mm from the top edge of the uppermost extension tube.

The expansion joint seal should be applied to the outside diameter of the tube in the following manner:

Remove the backing strip from the expansion joint seal and adhere it 25mm from the top edge of the tube. The seal should wrap twice around the tube, not overlapping but butting up closely (**diagram J**).

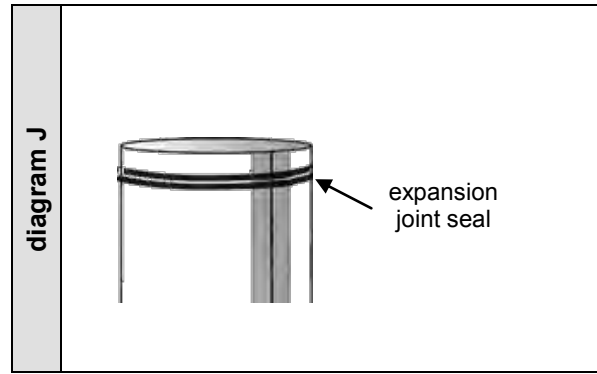

Step 13 Installing the bottom tube assembly

If any angle adjustment is required to the bottom tube assembly to align it with the top tube assembly this should be done now; use a crosshead screwdriver to loosen the twist-lock fastening clamps. Remove the assembly from the ceiling, and rotate the angle adaptor if necessary to ensure alignment with the top tube assembly.

If extension tubes are being used go to Step 14.

If no extension tubes are being used, re-insert the bottom tube assembly, sliding it up into the top tube assembly and then lock all four twist-lock fastening clamps into the ceiling (**diagram K**).

Note: If the ceiling clamps cannot be engaged owing to the thickness of the ceiling or because of proximity to joists, the bottom tube assembly can be screwed with the screws provided into the ceiling/joists through the pre-drilled screw holes in the ceiling flange.

Do not over tighten the bottom tube assembly to the ceiling as this may prevent fitting of the diffuser.

Remove the protective film from the inside of the bottom tube assembly.

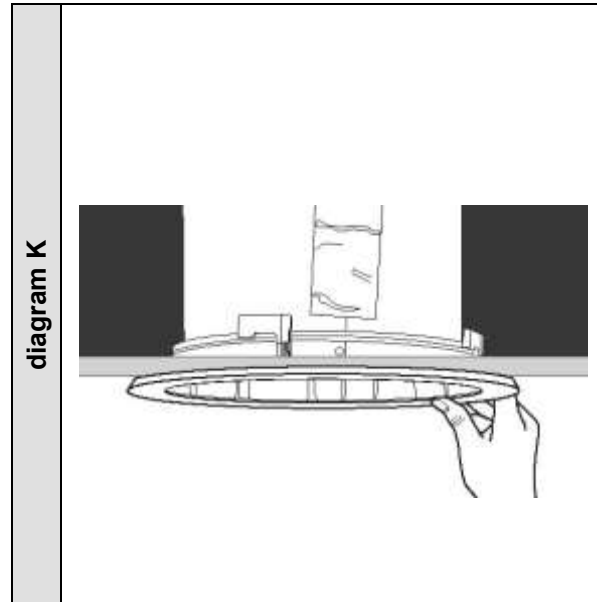

Step 14 Installing extension tubes

For installations with extension tubes, remove the protective film from the inside of the bottom tube assembly and all other tubing if not already done so. Re-insert the bottom tube assembly and then lock all twist-lock fastening clamps into the ceiling.

Insert the extension tube with the expansion joint seal (**a**) up into the top tube assembly. Then insert the other end (**b**) into the bottom tube assembly (**diagram L**). Ensure there is a minimum 50mm overlap at either end. Tape all joints together and use self tapping screws for additional rigidity if necessary.

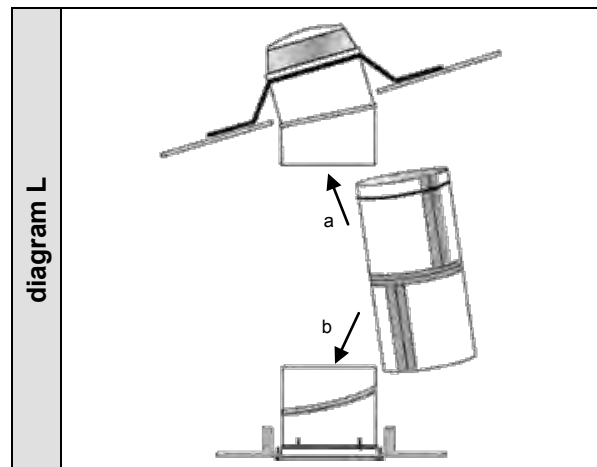

Step 15 – Diffuser installation

Align the diffuser to the bottom tube assembly. Apply firm upward pressure on the white dress ring of the diffuser until it „snap fits“ into position, taking care not to push on the central diffusing area (**diagram M**). The diffuser is held in place by an interference fit in the bottom tube assembly and can be removed if required by pulling down on the outside of the white dress ring until it „snaps“ free.

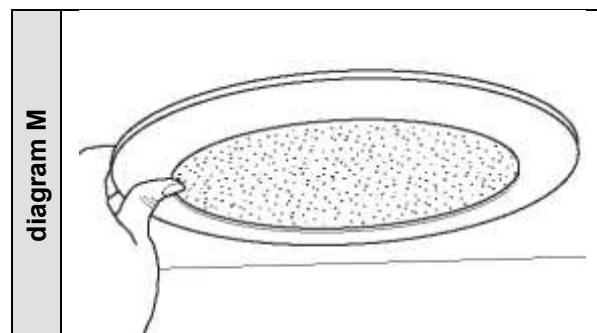

Brighten Up® Series installation guide

Solatube roof flashings

Please ensure you have the correct roof flashing before proceeding and read these instructions in conjunction with the warnings, installation tips and safety advice on page 2.

These instructions cover typical applications. In some instances, roof tiles may need to be trimmed and roof structures may be different to those described. Please contact your Solatube supplier before proceeding if you have any questions regarding the installation of these roof flashings.

Flat roof

Page 8



Solatube 160 DS and 290 DS

Slate/plain tile

Page 9



Solatube 160 DS and 290 DS

Interlocking tile

Page 10



Solatube 160 DS and 290 DS

Single tile flashing

Page 11



Solatube 160 DS only

Curb mount

Page 12



Solatube 290 DS only

Turret extension

Page 12



Solatube 160 DS and 290 DS

Flat roof flashing



Parts list

	Qty
Tile flashing	1
Flashing screws 50mm (in fastener kit)	8
Flashing screws 50mm (in flashing kit)	8
Geocel cartridge	1

First complete the Solatube 160DS or 290DS installation instructions Steps 1- 4

These flashing instructions cover a retrofit installation onto a felt roof. If the flat roof covering is being installed at the same time as the Solatube, it is possible to install the Solatube roof flashing to the decking, underneath the roofing material. Please refer to your Solatube supplier for more information.

Step A

Take the flashing, top tube assembly, tape, dome, LightTracker™, flashing screws, dome screws, Geocel and required tools onto the roof.

Step B

Locate the centre point above the hole cut in the ceiling, and mark with a nail or screw. Sweep away any loose gravel from the roof area where the flashing will be located. If the roof is felt or roll roofing, simply remove any dirt or loose granules with a wire brush. If the roof is hot tarred and gravel, scrape away the embedded gravel and excess tar with a flat or spud bar. The roof surface under the flashing and 75 mm beyond the edge must be smooth, level, clean and dry.

Step C

Drill eight 5mm diameter holes around the edge of the flashing base between the eight existing holes (**diagram 1**).

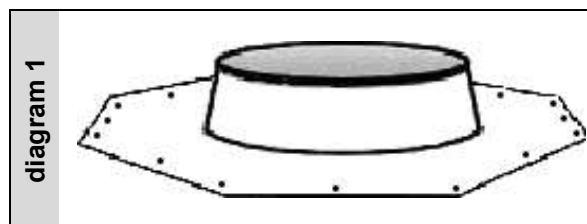

Step D

Centre the flashing over the locating nail or screw. Mark the inside circumference onto the roof surface and the outer edge of the flashing onto the roof to mark its final location. Remove the flashing and cut the inner circumference hole through the roof deck, 20mm inside the inner marked line. Clean the sawdust from around the roof hole.

Step E

Apply a generous bead of Geocel sealant to the roof, 25mm inside the perimeter of the outer edge flashing mark. Also apply a generous bead of Geocel sealant on the underside of the flashing, 25mm in from the outside edge (**diagram 2**). Lower the flashing into its marked position and make sure that it is seated correctly and the Geocel sealant has made a complete and watertight seal.

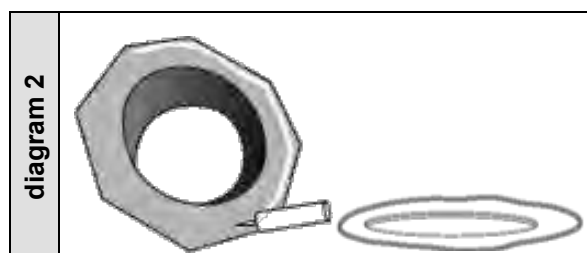

Step F

Fasten the flashing to the roof with the 50mm flashing screws provided. Screws should be firm, but not over tight (**diagram 3**). Apply another bead of sealant to the outer edge of the flashing, spreading it evenly to seal the flashing edge to the roof surface. Apply sealant to all flashing screw heads. If the roof is a gravel roof, sweep gravel back over the base of the flashing.

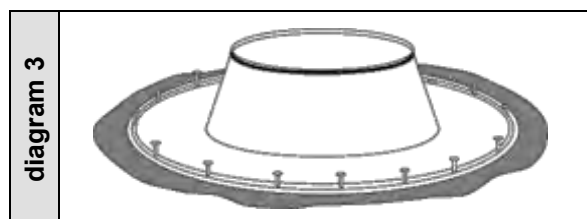

Please now continue to Step 6 of the Solatube 160DS or 290DS installation instructions

Slate and plain tile flashing

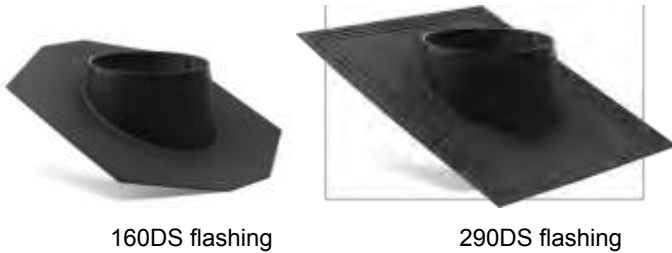

160DS flashing

290DS flashing

Parts list

	Qty
Tile flashing	1
Flashing screws 50mm (in fastener kit)	8
Flexseal cartridge	1

First complete the Solatube 160DS or 290DS installation instructions Steps 1- 4

Step A

Take the flashing, top tube assembly, tape, dome, flashing screws, LightTracker™, dome screws, Flexseal and required tools onto the roof.

Step B

Locate your marker and remove sufficient tiles to allow you to place the top and aperture of the flashing onto the roof battens, leaving sufficient tiles at the bottom edge to allow the flashing to overlap sufficiently onto the tiles below. Double-check that no rafters or obstructions lie behind the proposed tube position (**diagram 1**). The tile pattern & size of tile will determine how many tiles need to be replaced and/or cut to size.

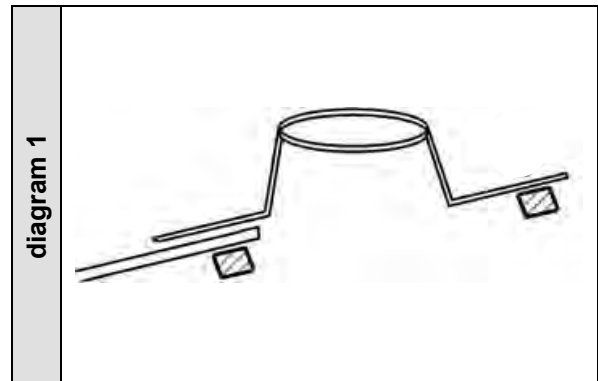

Step C

Place the flashing to one side. Cutting obstructing battens if necessary, cut through the roof felt in a star shape (**diagram 2**) so the felt can be folded upwards and back on itself. Replace the flashing over the hole and temporarily insert top tube into the turret to check clearance and to angle the tube towards the bottom tube assembly in the ceiling.

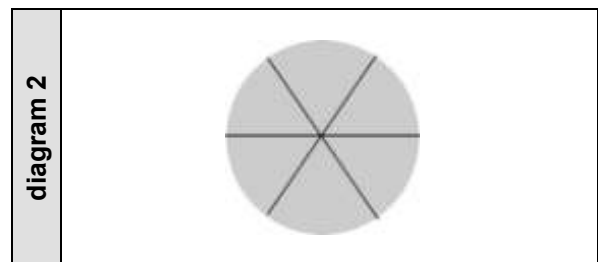

Step D

Using the flashing screws provided, secure the top of the flashing to the appropriate batten and use a small amount of sealant to cover each screw head. Apply a line of Flexseal sealant to the side sections of the flashing onto which the tiles will be re-laid (**diagram 3**).

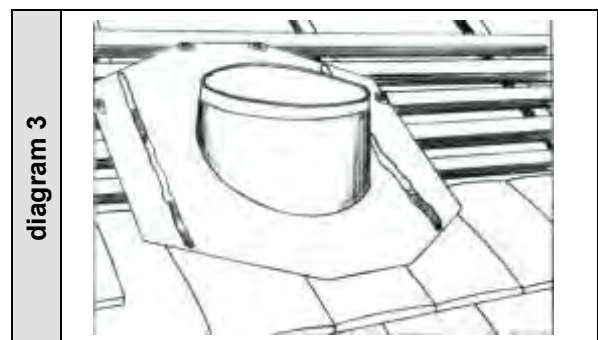

Step E

Apply a line of Flexseal sealant at the bottom edge of the flashing between the flashing and the tiles underneath, and across the top edge of the flashing. Re-lay and fix the tiles to the sides and top of the flashing ensuring there is a 40mm gap behind the flashing upstand to allow the top tube assembly, dome ring and dome to be inserted into the flashing upstand - note you may need to trim the tiles to achieve this. Ensure all tiles are firmly in position and the roof is fully watertight (**diagram 4**).

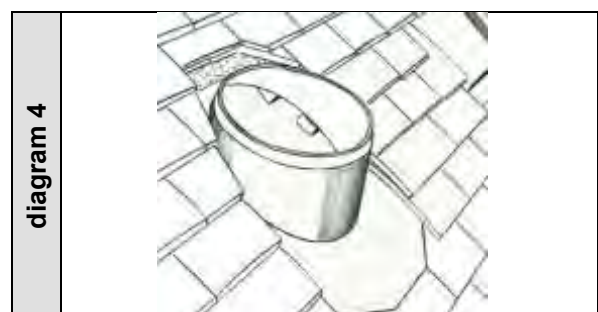

Please now continue to Step 6 of the Solatube 160DS or 290DS installation instructions

Interlocking tile flashing - universal



(picture shows offset flashing, parallel upstand flashing also available for low pitched roofs)

Parts list

	Qty
Tile flashing (pitched or non-pitched version)	1
Aluminium „L“ brackets	4
6mm screws	8
Flashing screws 50mm (in fastener kit)	8

Note: Do not use Portland Cement based mastic, grout or alkaline materials with this product. Caustic alkalis present in fresh, unhardened mortar will attack the flexible aluminium base.

First complete the Solatube 160DS or 290DS installation instructions Steps 1- 4

Step A

Take the flashing, top tube assembly, tape, dome, flashing screws, LightTracker™, dome screws, and required tools onto the roof.

Step B

Locate your marker and remove sufficient tiles to allow you to place the top and aperture of the flashing onto the roof battens, leaving sufficient tiles at the bottom edge to allow the flashing to overlap sufficiently onto the tiles below. Double-check that no rafters or obstructions lie behind the proposed tube position. Using the flashing as a template, draw around the inside circumference of the turret onto the roof felt (**diagram 1**).

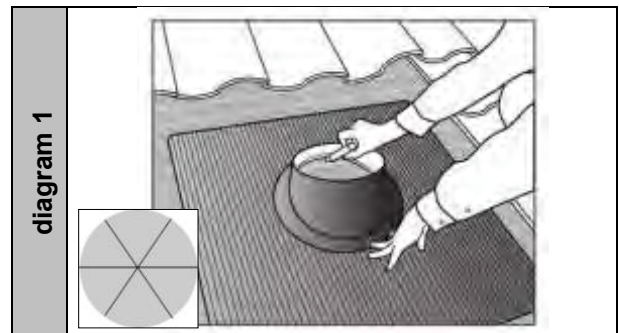

Step C

Place the flashing to one side. Cutting obstructing battens if necessary, cut the roof felt in a star shape (**diagram 1**) so the felt can be folded upwards and back on itself. Replace the flashing over the hole and temporarily insert top tube into the turret to check clearance and to angle the tube towards the bottom tube assembly in the ceiling.



Step D

Secure the top of the flashing to the roof battens using the screws provided. Apply hand-pressure to form the bottom edge of the flashing over the shape of the tiles beneath it. Turn up the left and right edges of the flashing to ensure water cannot ingress. (**diagram 2**).

Step E

Fix the aluminium „L“ brackets to secure the exposed lower end of the flashing to the tiles (refer to the instructions supplied with the „L“ brackets).

Replace and secure the removed tiles, ensuring a 40mm gap is left behind the turret upstand to allow the top tube assembly, dome ring and dome to be inserted into the flashing upstand – note, you may need to trim the tiles to achieve this. Mould the top of the flashing as necessary to fit the underside shape of the tiles. Ensure all tiles are firmly in position and the roof is fully watertight (**diagram 3**).

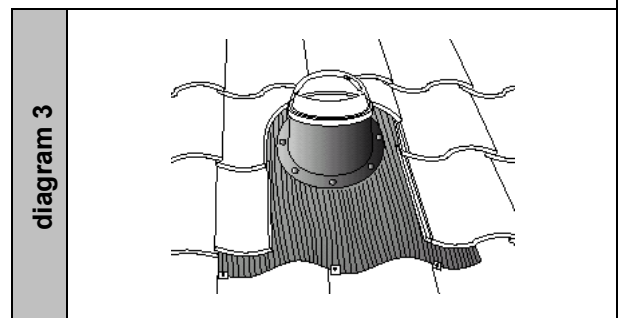

Please now continue to Step 6 of the Solatube 160DS or 290DS installation instructions

Interlocking tile flashing – single tile



Parts list

Tile flashing
Wire for fixing (not provided)

Qty
1

Note: This flashing replaces one complete profiled or flat interlocking tile for tiles 300mm visible width plus 30mm interlocking gully, total width 330mm eg:

Redland: Grovebury, 50 Double Roman, Regent, Renown

Marley: Ludlow major, Mendip, Double Roman, Malvern

Alternatively use the interlocking tile flashing – universal (page 10).

First complete the Solatube 160DS or 290DS installation instructions Steps 1- 4

Step A

Take the flashing, top tube assembly, tape, dome, dome screws, flashing screws, LightTracker™, and required tools onto the roof.

Step B

Locate your marker and remove the tile to be replaced. Double-check that no rafters or obstructions lie behind the proposed tube position. You may also need to temporarily remove or slide away the tiles above and to the left of the tile being replaced (**diagram 1**).

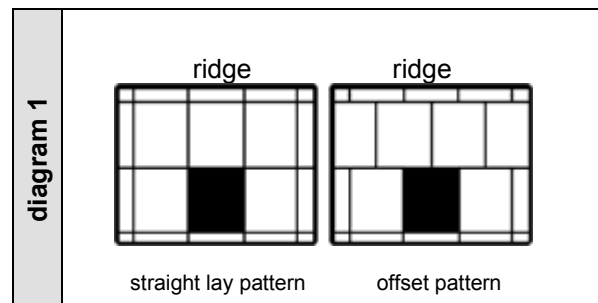

Step C

Using the flashing as a template, draw around the inside circumference of the turret onto the roof felt. Place the flashing to one side. Cutting obstructing battens if necessary, cut the roof felt in a star shape (**diagram 2**) so the felt can be folded upwards and back on itself. Replace the flashing over the hole and temporarily insert top tube into the turret to check clearance and to angle the tube towards the bottom tube assembly in the ceiling.

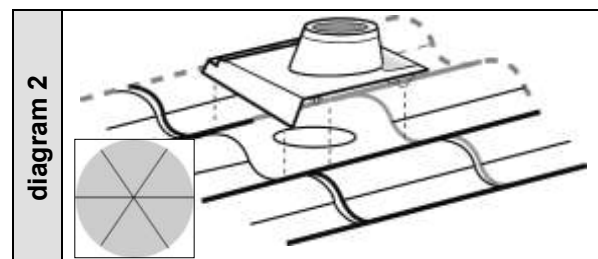

Step D

The flashing skirt needs to be cut to the same profile as the tiles it is sitting on (profiled or flat). Mark the profile of the lower roof tile onto the front skirt of the flashing (and rear skirt if necessary). Remove the flashing and file or cut the skirt along the line marked so the flashing sits on the tiles below (and above if necessary) with no gaps. Interlock the flashing to secure it into place (**diagram 3**).

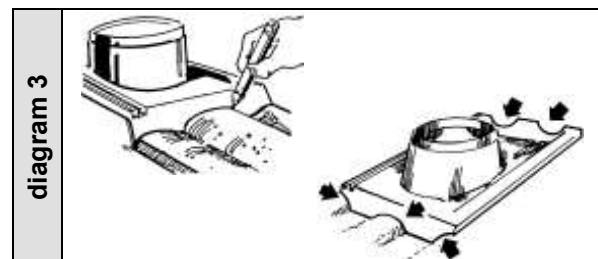

Step E

The flashing will be held in place by the weight of the tiles to the left and behind, but the bottom right hand corner needs to be secured. This is done by drilling through the lugs on the underside of the flashing and wiring through the lugs and around the closest batten (**diagram 4**). Ensure the flashing and tiles are firmly in position and the roof is fully watertight.

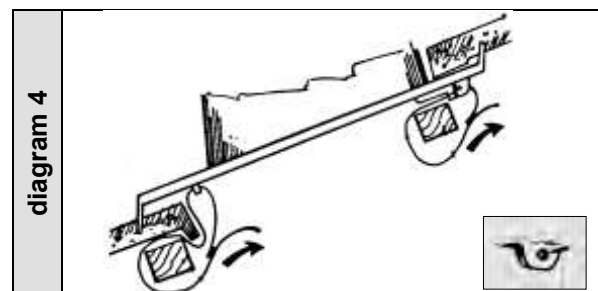

Please now continue to Step 6 of the Solatube 160DS or 290DS installation instructions

Curb mount flashing



Parts list

	Qty
Tile flashing	1
Geocel sealant	1
Flashing screws 50mm (in fastener kit)	8

First complete the Solatube 160DS or 290DS installation instructions Steps 1- 4

Step A

Take the flashing, top tube assembly, tape, dome, LightTracker™, flashing screws, dome screws, Geocel and required tools onto the roof.

Step B

Centre the curb mounted flashing onto the pre-constructed or manufactured curb. Check that flashing fits and that there are no obstructions in the path of the tube (**diagram 1**). Allow sufficient gap between the flashing and curb upstand for the roofing material.

Run a generous line of Geocel sealant on the top of the curb where it will make contact with the underside of the flashing to seal. With the flashing screws provided, secure the sides of the flashing into the curb upstand. Ensure the flashing is firmly in position and the roof is fully watertight.

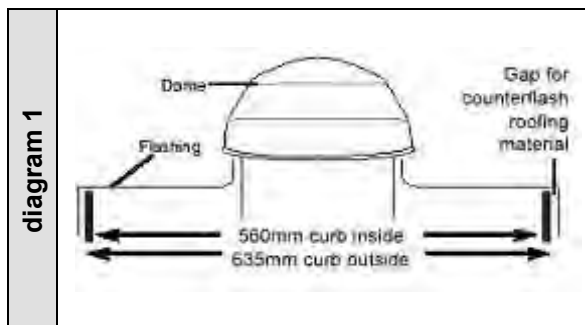

Please now continue to Step 6 of the Solatube 160DS or 290DS installation instructions

Turret extension



50mm turret extension shown – other sizes available please contact your Solatube supplier for more details

Parts list

	Qty
Turret extension	1
Geocel sealant	1
6mm screws	4

This procedure is for Solatube installations where additional turret height is needed on roof installation.

First complete the Solatube 160DS or 290DS installation instructions Steps 1- 5

Step A

Apply a bead of Geocel sealant around the outside of the top edge of the flashing upstand. Place the turret extension over the flashing upstand, aligning the pre-drilled holes and push down until the inside of the turret extension contacts the top of the flashing upstand (**diagram 1**). Fasten the turret extension to the flashing upstand with the four 6mm screws. Ensure that the Geocel sealant has made a watertight seal and remove any excess Geocel sealant inside and outside the turret. Seal the heads of the screws with Geocel sealant.

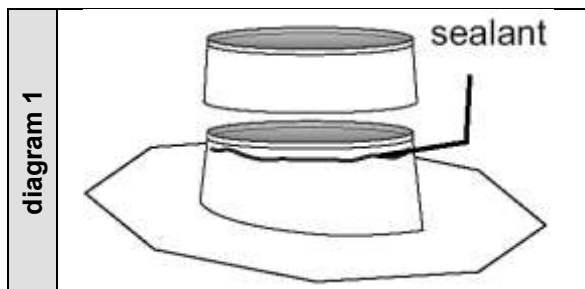

Please now continue to Step 6 of the Solatube 160DS or 290DS installation instructions