

SolaMaster® Series Material Specifications:

1. Dome is UV and impact resistant for extended service life. Its low profile design is unobtrusive. Impact modified, polycarbonate. Classified as TP(a) material, 4mm thick, with visible light transmission of 92% and ultra violet light transmission of .03%.
2. LightTracker™ Reflector increases daylight collection and harvesting for low sun angles, resulting in increased light output. Spectralight® Infinity. For specifications see # 6 below.
3. Permeable Dome Seal locks out dust and insects, but allows moisture to escape. Black breathable weatherstrip material with 10mm pile.
4. Dome Ring and Dome Seal to channel condensed moisture out of the system. Durable white PVC, injection moulded non-corrosive material.
5. One-Piece Seamless Flashing, 100mm-, 200mm- and 280mm- high ensures a no-leak installation. 0.75mm thick aluminiumized steel with powder coated exterior.
6. The 30-degree Angle Adaptors feature 30-degree elbows for easy installations. The diameter tubes fit between 24" (600 mm) on centre framing. Angle adaptors use Spectralight® Infinity for a reflective surface.

Spectralight® Infinity material, fabricated from aluminium sheet meeting ASTM B 209 requirements, alloy and temper required by the manufacturer to suit forming operations and finish requirements, 0.46mm thick.

Interior Finish: Spectralight Infinity high reflectance specular finish on exposed reflective surface; Visible spectrum (400 nm to 760 nm) greater than 99%; Total solar spectrum (400 nm to 2500 nm) less than 93%.

Colour: a* and b* (defined by CIE L*a*b colour model) shall not exceed plus 2 or be less than minus 2 as determined in accordance to ASTM E 308.

7. Extension Tubes are 610 mm in length, for installations up to 15m. Spectralight® Infinity.
8. 600mm x 600mm Transition Box (21-C only). Fits a standard suspended ceiling system. Polycarbonate OptiView™ material, classified as TP(a).
9. Square Diffuser Panel fits into the transition box and complements traditional light fixtures. UV and weather resistant diffuser seal provides an effective dust and insect seal.

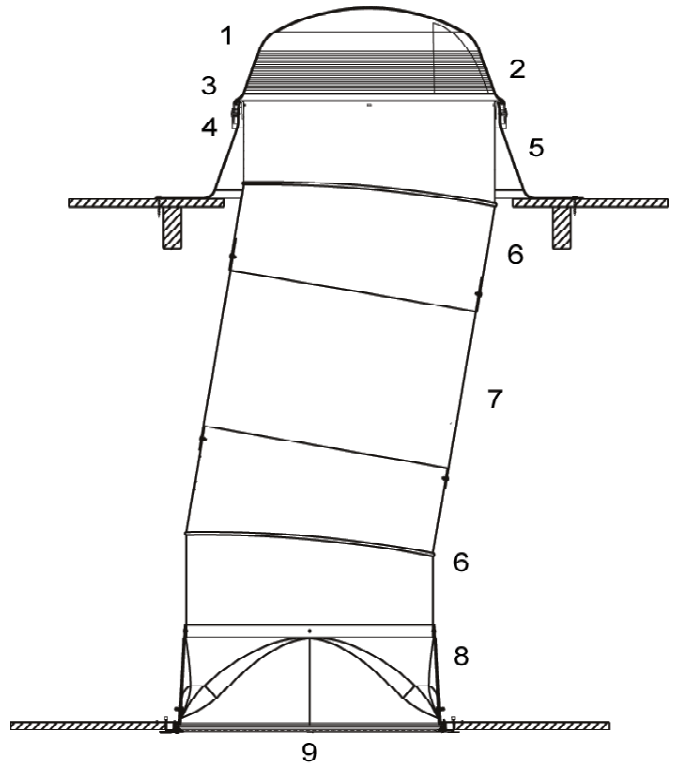

SolaLighting Limited, 23 Osier Way, Olney Office Park, Olney, MK46 5FP

Tel: 01234 241466 Fax: 01234 241766

Email: daylight@solatube.co.uk

Website: www.solatube.co.uk